

M series motors

CHARACTERISTICS OF THE M SERIES MOTORS

| Motor model | Displacement (cc/rev) | Continuous max. speed (1) (rpm) | Intermittent max. speed (1) (rpm) | Max. flow absorbed (l/mn) | Torque (N.m/bar) | Torque at 350 bar (N.m) | Theoretical maximal power at 400 bar (kW) | Max. allowable pressure continuous / peak (bar) | Weight (kg) |
|-------------|-----------------------|---------------------------------|-----------------------------------|---------------------------|------------------|-------------------------|---|---|-------------|
| M 5_093840 | 5 | 8000 | 8800 | 40 | 0.08 | 28 | 26.6 | 400 / 450 | 4.4 |
| M 12 | 12 | 8000 | 8800 | 96 | 0.19 | 67 | 64 | 400 / 450 | 5.5 |
| M 18 | 18.0 | 8000 | 8800 | 144 | 0.29 | 100 | 96 | 400 / 450 | 5.5 |
| M 25 | 24.9 | 6300 | 6900 | 157 | 0.40 | 139 | 104.5 | 400 / 450 | 11.5 |
| M 28 | 27.7 | 6300 | 6900 | 175 | 0.44 | 154 | 116.3 | 400 / 450 | 11.5 |
| M 32 | 32.1 | 6300 | 6900 | 202 | 0.51 | 179 | 134.8 | 400 / 450 | 11.5 |
| M 41 | 41.1 | 5600 | 6200 | 230 | 0.65 | 229 | 153.4 | 400 / 450 | 11.5 |
| M 45 | 45.4 | 5000 | 5500 | 227 | 0.72 | 253 | 151.3 | 400 / 450 | 18 |
| M 50 | 50.3 | 5000 | 5500 | 252 | 0.80 | 280 | 167.6 | 400 / 450 | 18 |
| M 63 | 63 | 5000 | 5500 | 315 | 1.00 | 351 | 210 | 400 / 450 | 18 |
| M 80 | 80.4 | 4500 | 5000 | 362 | 1.28 | 448 | 241.2 | 400 / 450 | 23 |
| M 90 | 90 | 4500 | 5000 | 405 | 1.43 | 501 | 270 | 400 / 450 | 23 |
| M 108 | 108.3 | 4000 | 4400 | 433 | 1.72 | 603 | 288.8 | 400 / 450 | 23 |
| M 108 R (2) | 108.3 | 3400 | 4500 | 368 | 1.72 | 603 | 245.4 | 400 / 450 | 35 |
| M 125 | 125.4 | 3400 | 4500 | 426 | 2.00 | 699 | 284.2 | 400 / 450 | 35 |
| M 160 | 160 | 3600 | 4000 | 576 | 2.55 | 891 | 384 | 400 / 450 | 48.5 |
| M 180 | 180.6 | 3600 | 4000 | 650 | 2.87 | 1006 | 433.4 | 400 / 450 | 48.5 |

(1) For higher speeds, please contact us.

(2) The M 108 R motor is in the frame size of the M 125.

► Acceptable forces applied to motor shaft

| Motor model | | 5 | 12 | 18 | 25 | 28 | 32 | 41 | 45 | 50 | 63 | 80 | 90 | 108 | 108 R | 125 | 160 | 180 |
|-------------|---------|-----|------|------|------|------|------|------|------|------|------|-------|-------|-------|-------|-------|-------|-------|
| Fr | N | 710 | 2800 | 4000 | 6000 | 6200 | 6500 | 7000 | 6500 | 7500 | 9000 | 10500 | 11000 | 11500 | 12500 | 14500 | 18000 | 20000 |
| Fa | N/bar * | 10 | 15 | 20 | 27 | 28 | 30 | 40 | 40 | 40 | 50 | 60 | 67 | 80 | 80 | 86 | 85 | 95 |

Fr: radial force measured at mid point of length of shaft.

Fa: axial force which tends to push the shaft inwards.

* Differential pressure between A and B.

For other forces, please contact us.

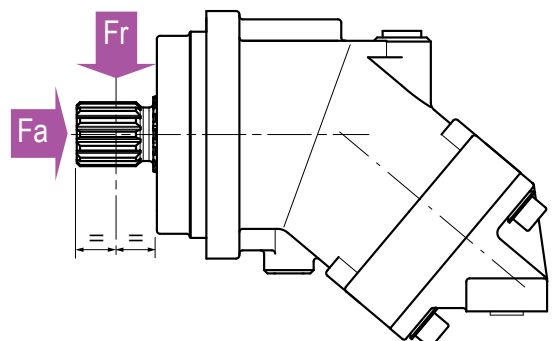

Order code system of M series motors

| M | ... | A | .. | .. | M2 | . | . | .. | .. |
|----|-----|----|----|----|----|----|----|----|----|
| 01 | 02 | 03 | 04 | 05 | 06 | 07 | 08 | 09 | 10 |

To obtain the code for your motor, complete the different parameters 02, 04, 05, 07, 08, 09 and 10 in the table on the left according to the options you require (see table below).

| Motor | |
|-------|-------|
| 01 | Motor |

| Displacement | |
|--------------|---|
| 02 | 5 12 18 25 28 32 41 45 50 63 80 90 108 108R 125 160 180 |

| Mounting flange | |
|-----------------|----------------------------------|
| 03 | CETOP 2/bolts 4 bolts ISO 3019-2 |

| Shaft | | | | | | | | | | | | | | | | | | | | |
|-------|------------------|------|------|------|------|------|------|------|------|------|------|------|------|------|------|------|------|------|------|----|
| 04 | DIN 5480 splined | - | W25 | W25 | W25 | W30 | W30 | W30 | W30 | W30 | W30 | W30 | W40 | W40 | W40 | W45 | W45 | W50 | W50 | W1 |
| | | - | - | - | W30 | W25 | W25 | - | W35 | W35 | W35 | W35 | - | - | W40 | W40 | - | - | W2 | |
| | DIN 6885 keyed | Ø 18 | Ø 25 | Ø 25 | Ø 25 | Ø 30 | Ø 30 | Ø 30 | Ø 30 | Ø 30 | Ø 30 | Ø 30 | Ø 40 | Ø 40 | Ø 40 | Ø 45 | Ø 45 | Ø 50 | Ø 50 | D1 |
| | | - | Ø 20 | - | Ø 30 | Ø 25 | Ø 25 | - | Ø 35 | Ø 35 | Ø 35 | - | - | - | Ø 40 | - | - | - | - | D2 |

| Inlet ports A and B | | | | | | | | | | | | | | | | | | | | | | |
|---------------------|------------------|--------|---|---|---|---|---|---|---|---|---|---|---|---|---|---|---|---|---|---|----|----|
| 05 | SAE flange ports | Bottom | 0 | - | - | - | - | • | • | • | • | • | • | • | • | • | • | • | • | • | L0 | |
| | | Rear | 0 | - | - | - | • | • | • | • | • | • | • | • | • | • | • | • | • | • | • | M0 |
| | | Side | 0 | - | - | - | • | • | • | • | • | • | • | • | • | • | • | • | • | • | • | N0 |
| | 1 | | - | - | - | • | • | • | • | • | • | • | • | • | • | • | • | • | • | • | N1 | |
| | Threaded | Side | 0 | - | • | • | • | • | • | • | • | • | • | • | • | - | - | - | - | - | - | Q0 |
| | | | 1 | - | - | - | • | • | • | • | • | • | • | • | • | - | - | - | - | - | - | Q1 |
| Rear | | 0 | • | • | • | • | • | • | • | • | • | • | • | • | • | - | - | - | - | - | P0 | |

0 = Without suitability for valves
1 = Compatible with flushing valve

| Drain ports T1 and T2 | |
|-----------------------|--|
| 06 | 2 M2 |

| Suitable for use of speed sensor | | | | | | | | | | | | | | | | | | | | | | |
|----------------------------------|-----|---|---|---|---|---|---|---|---|---|---|---|---|---|---|---|---|---|---|---|---|---|
| 07 | Yes | - | • | • | • | • | • | • | • | • | • | • | • | • | • | • | • | • | • | • | • | 1 |
| | No | • | • | • | • | • | • | • | • | • | • | • | • | • | • | • | • | • | • | • | • | • |

| Speed sensor | | | | | | | | | | | | | | | | | | | | | | | |
|--------------|-----|---|---|---|---|---|---|---|---|---|---|---|---|---|---|---|---|---|---|---|---|---|---|
| 08 | Yes | - | • | • | • | • | • | • | • | • | • | • | • | • | • | • | • | • | • | • | • | • | 1 |
| | No | • | • | • | • | • | • | • | • | • | • | • | • | • | • | • | • | • | • | • | • | • | • |

| Valves | | | | | | | | | | | | | | | | | | | | | | | |
|--------|---------------------|---|---|---|---|---|---|---|---|---|---|---|---|---|---|---|---|---|---|---|---|---|----|
| 09 | Without | • | • | • | • | • | • | • | • | • | • | • | • | • | • | • | • | • | • | • | • | • | SV |
| | with flushing valve | - | - | - | • | • | • | • | • | • | • | • | • | • | • | • | • | • | • | • | • | • | VB |

| Low temperature option | | | | | | | | | | | | | | | | | | | | | | | |
|------------------------|-----------|---|---|---|---|---|---|---|---|---|---|---|---|---|---|---|---|---|---|---|---|---|---|
| 10 | Yes (NBR) | - | • | • | • | • | • | • | • | • | • | • | • | • | • | • | • | • | • | • | • | • | N |
| | No (FKM) | • | • | • | • | • | • | • | • | • | • | • | • | • | • | • | • | • | • | • | • | • | • |

PLEASE NOTE: The M5 motor, reference 093840, only exists in one version (see next page).

CETOP flange, 2 bolts

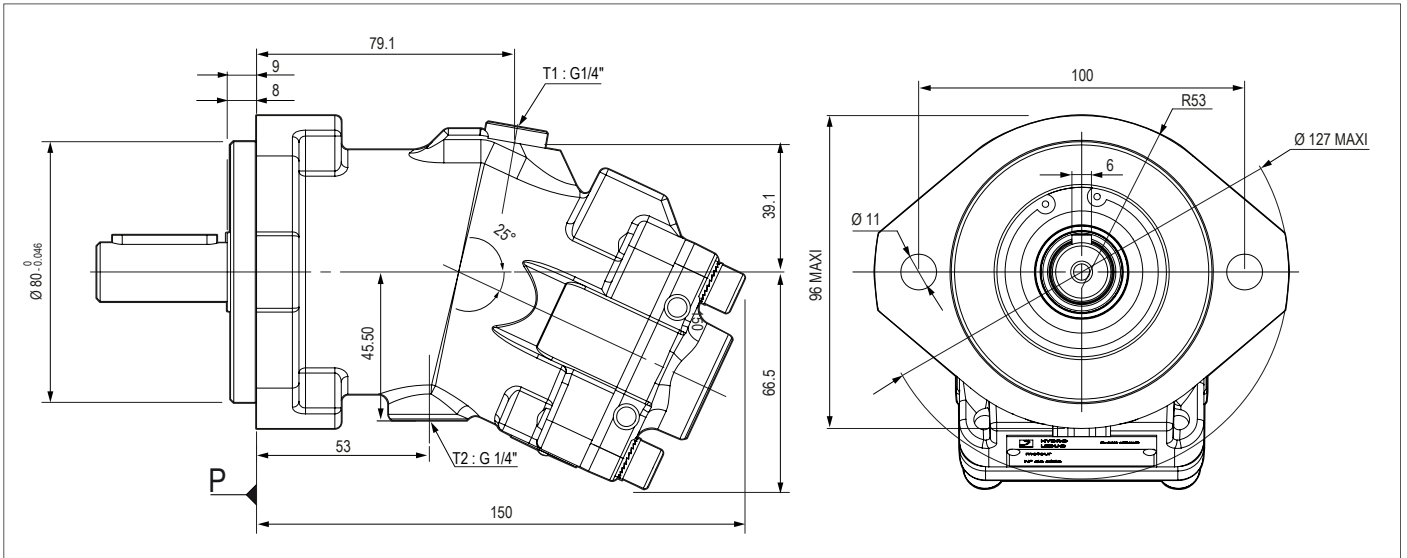

► Shaft end

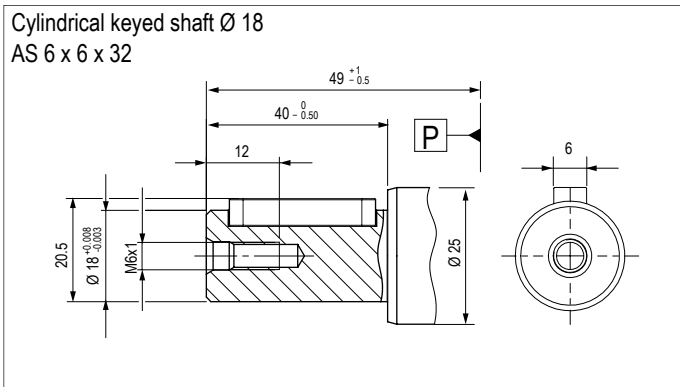

► Inlet ports

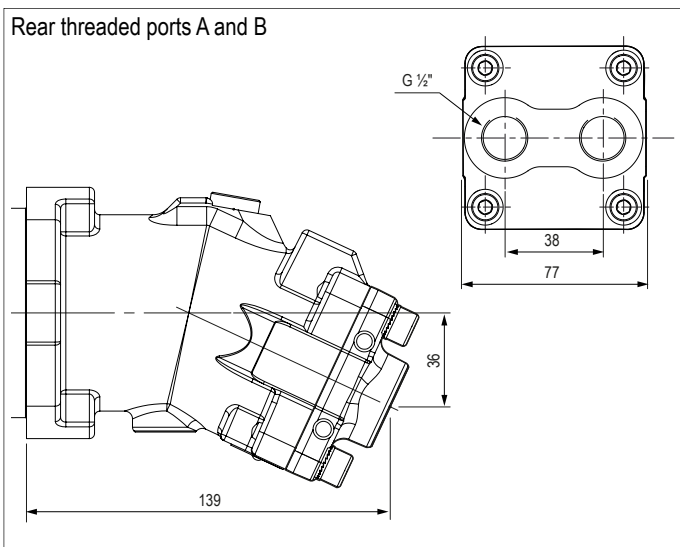

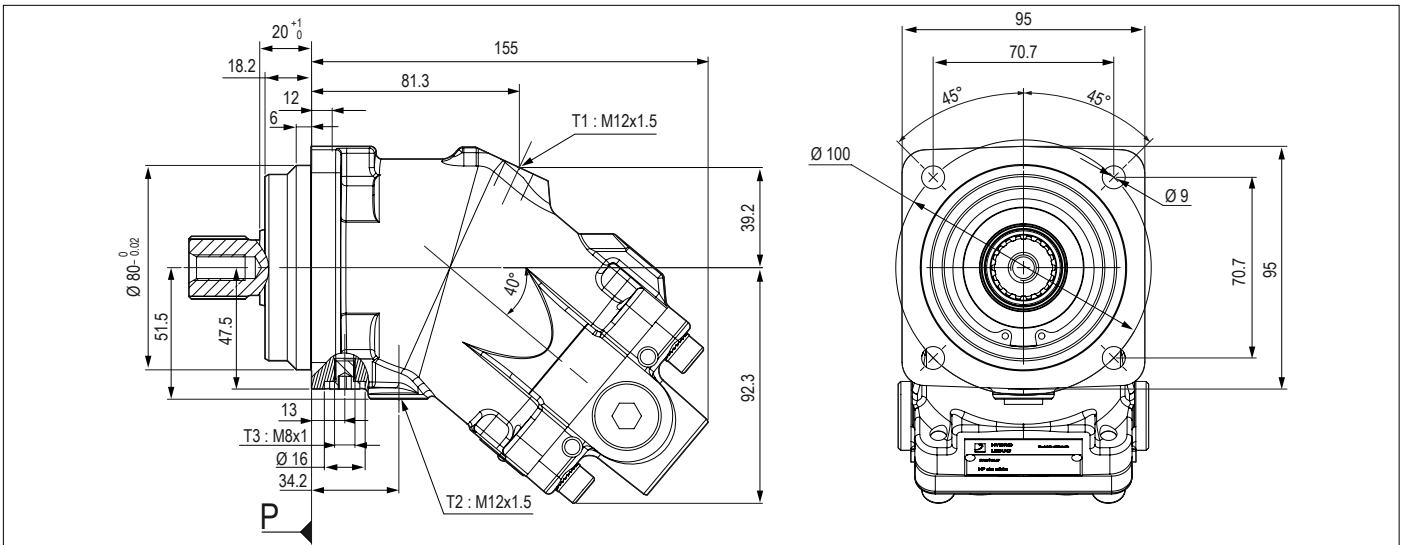

► Shaft

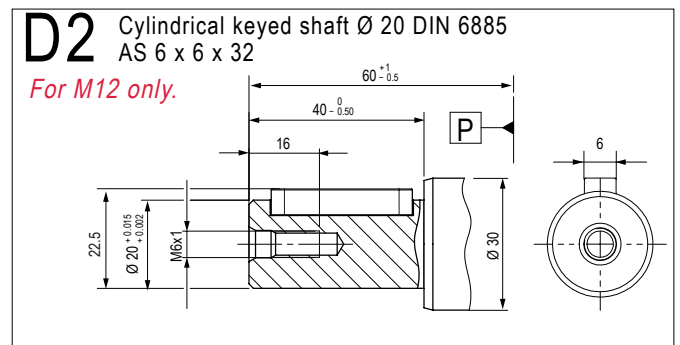
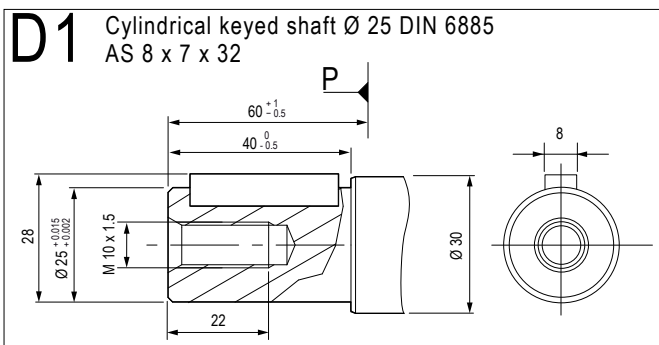
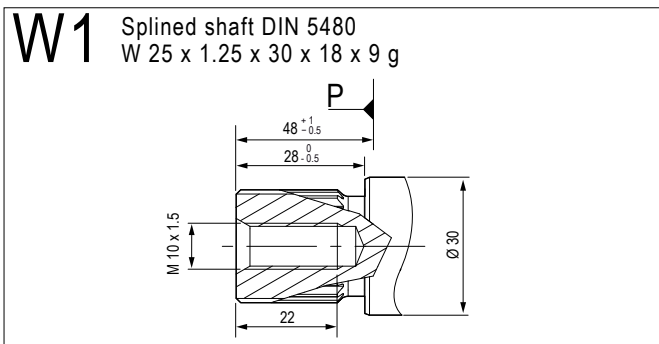

► Inlet ports

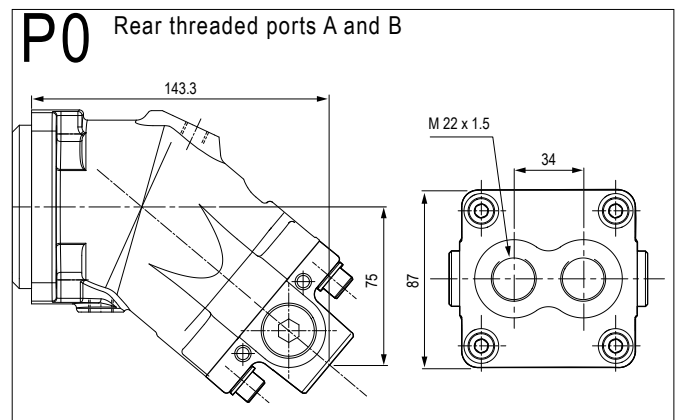
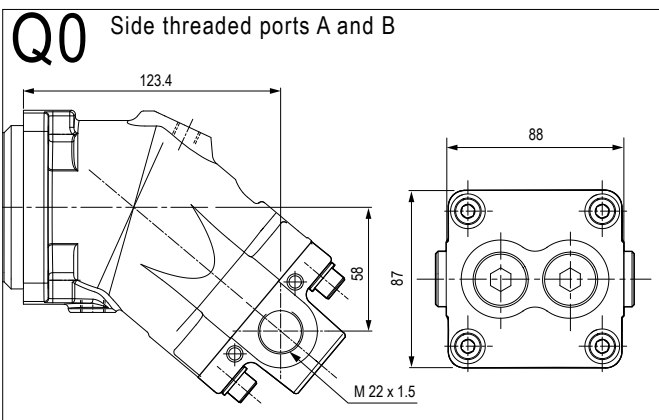

Dimensions in mm are given only as an indication.

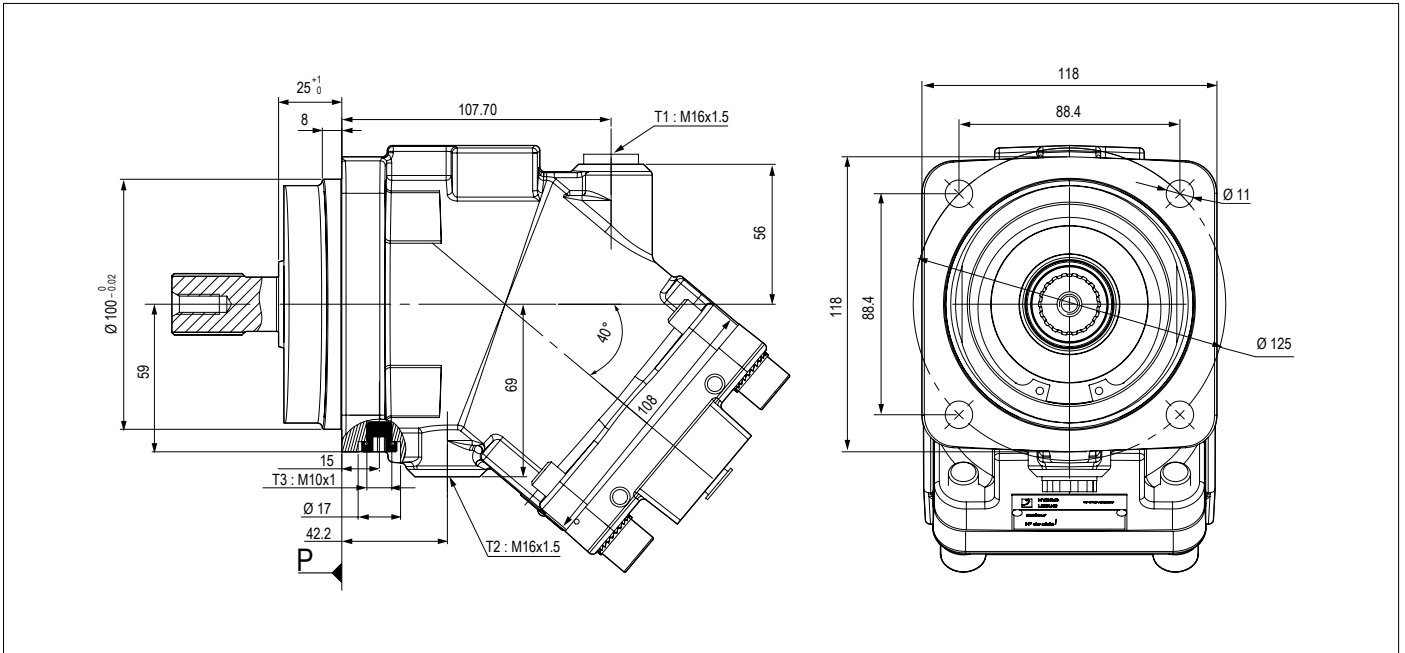

► Shaft end

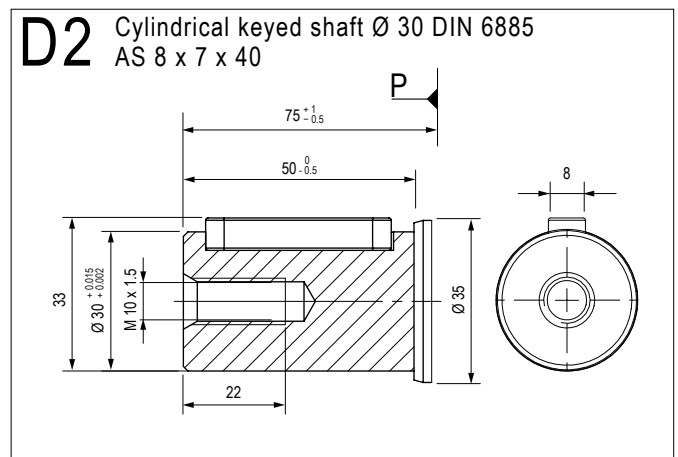
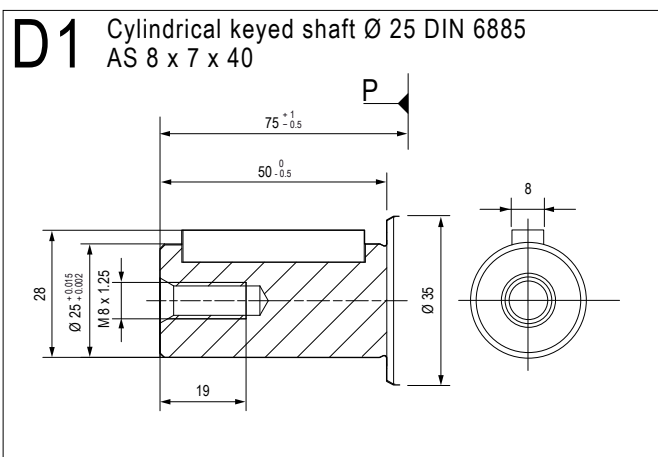
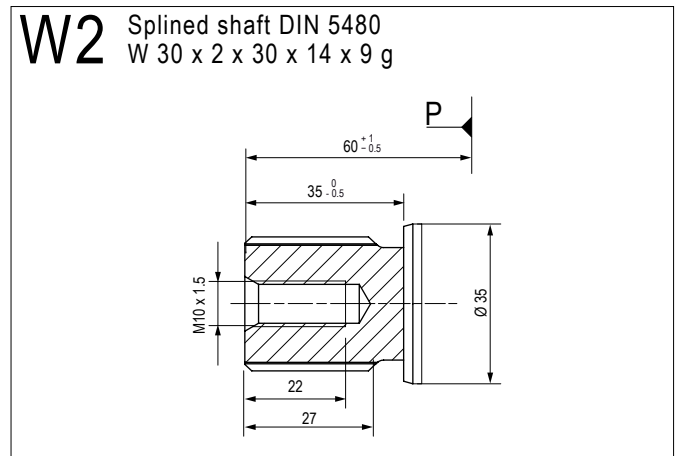
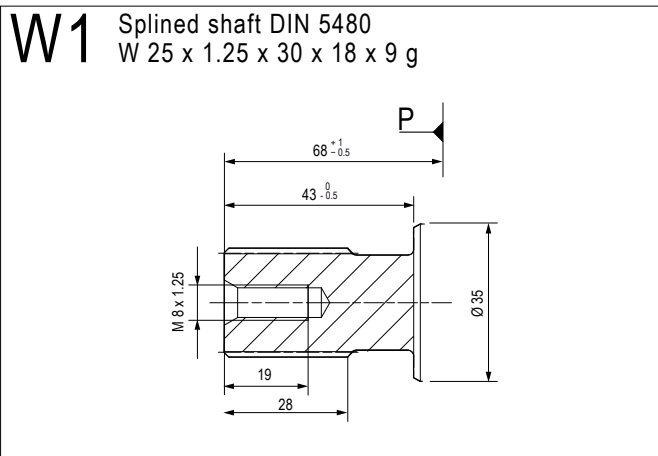

► Inlet ports

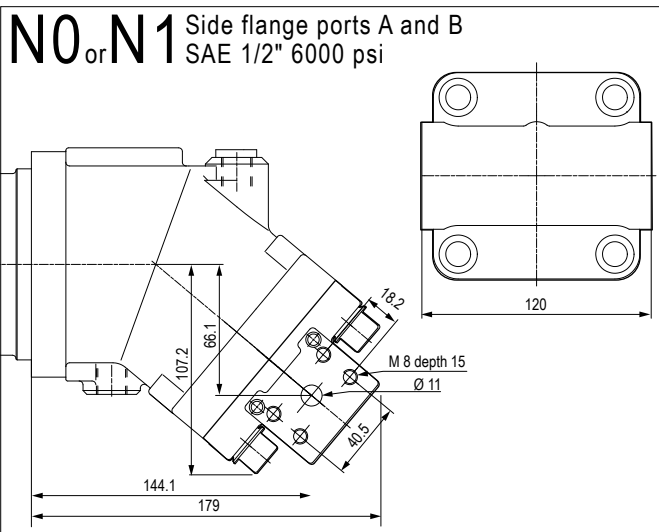
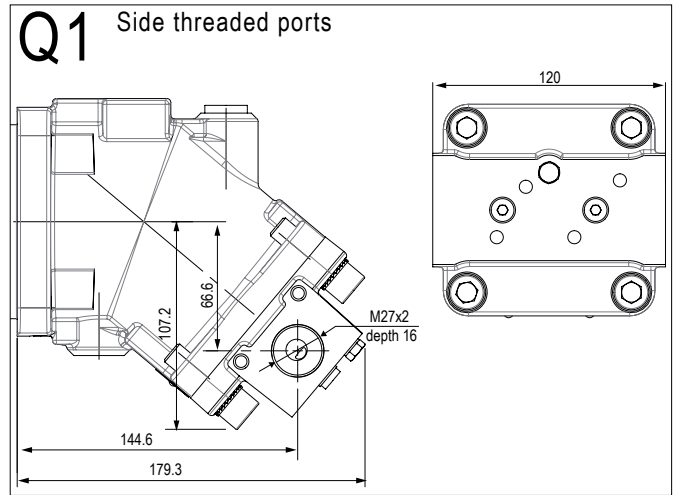
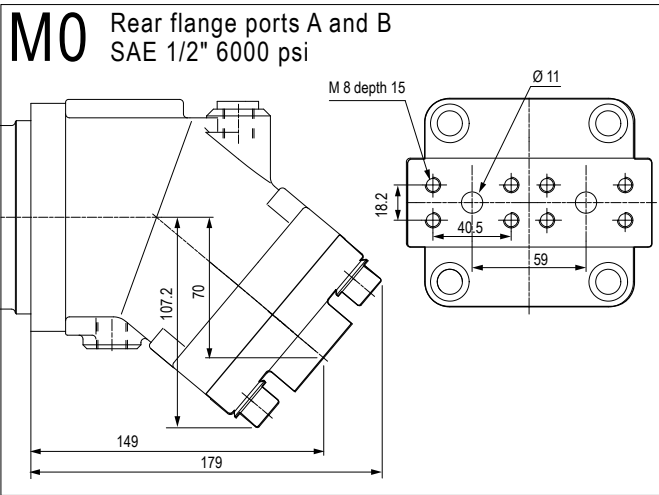
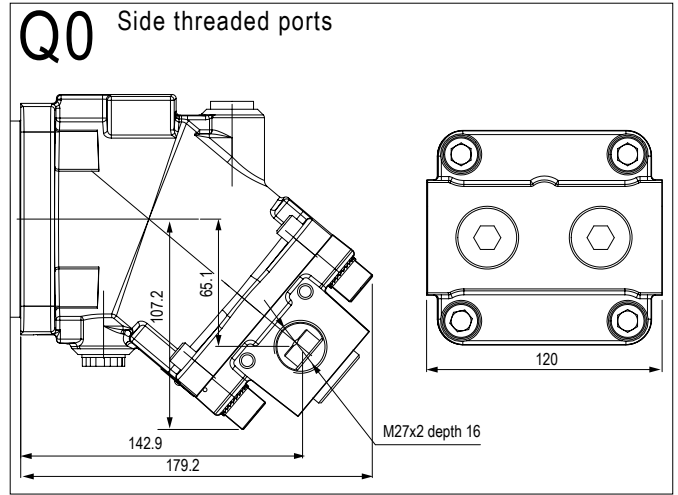
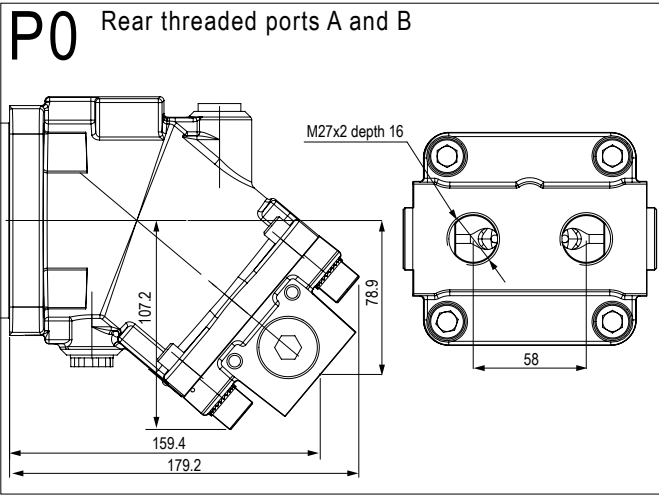

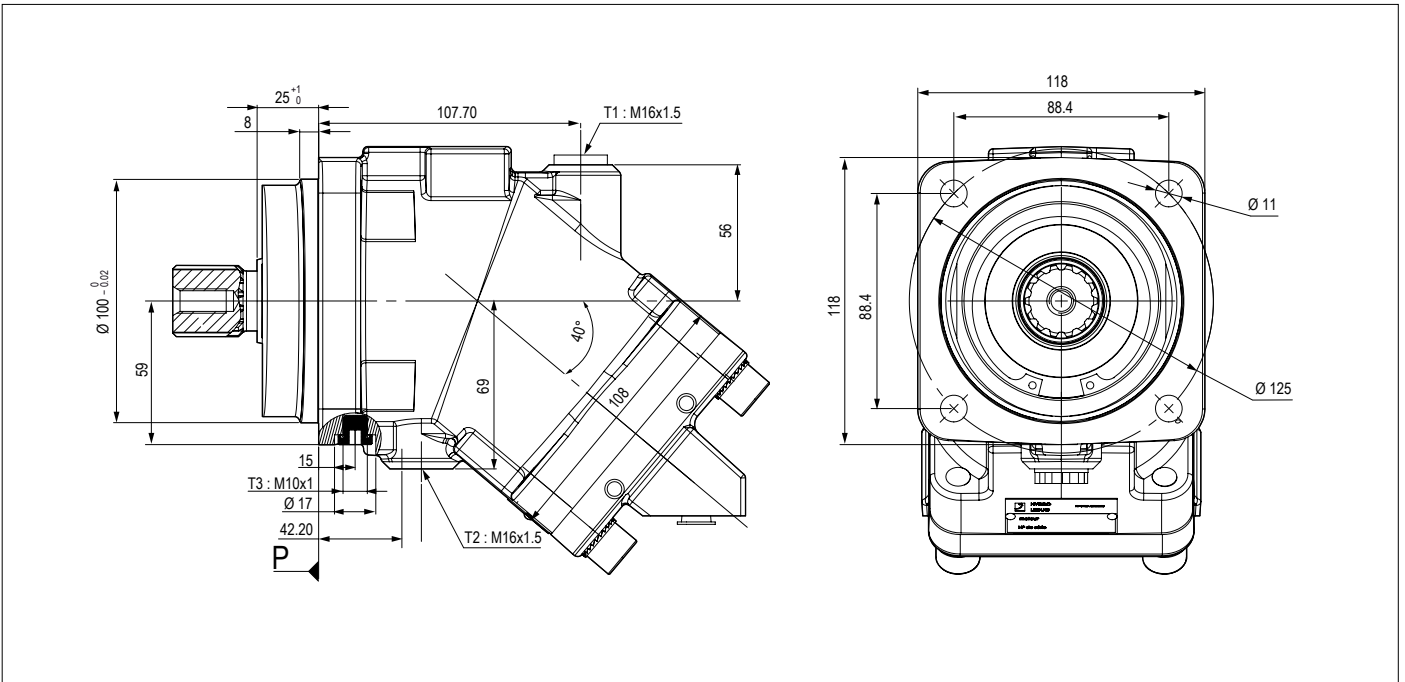

► Shaft end

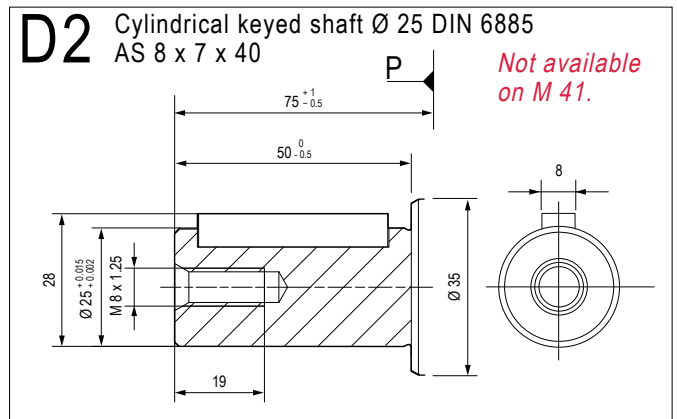
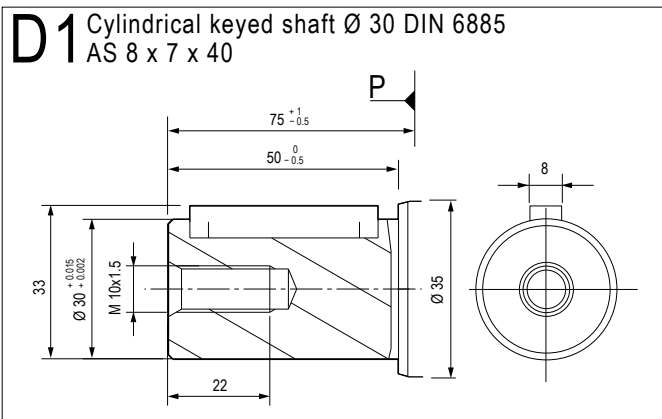
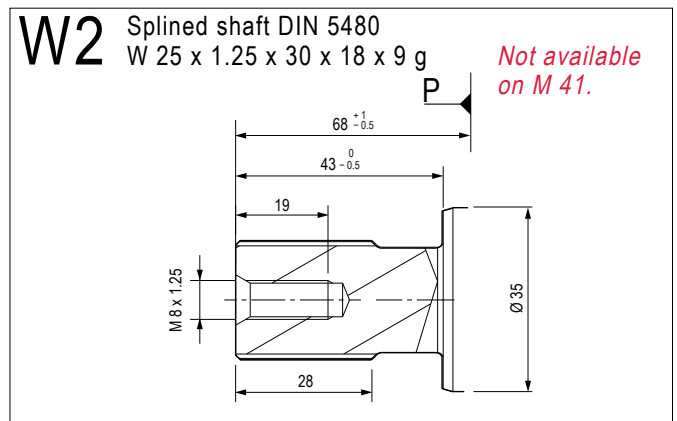
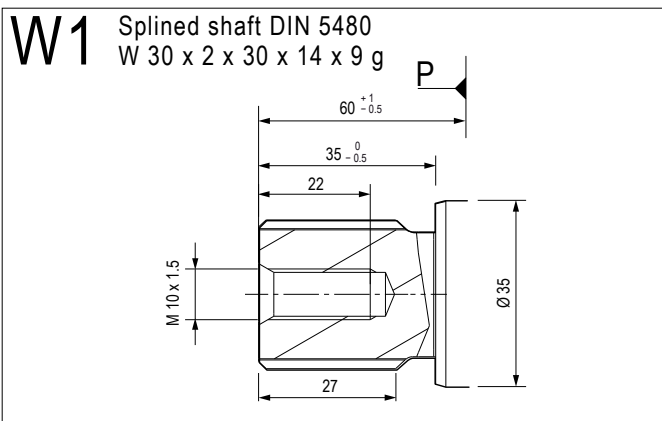

Dimensions in mm are given only as an indication.

► Inlet ports

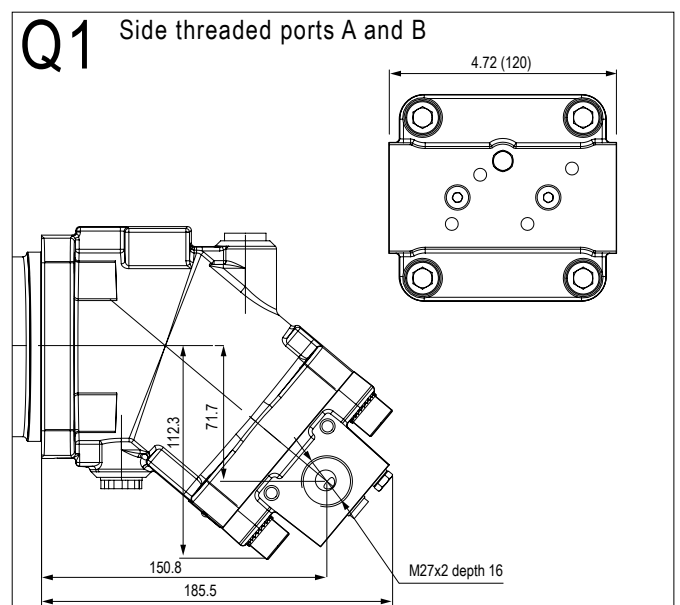
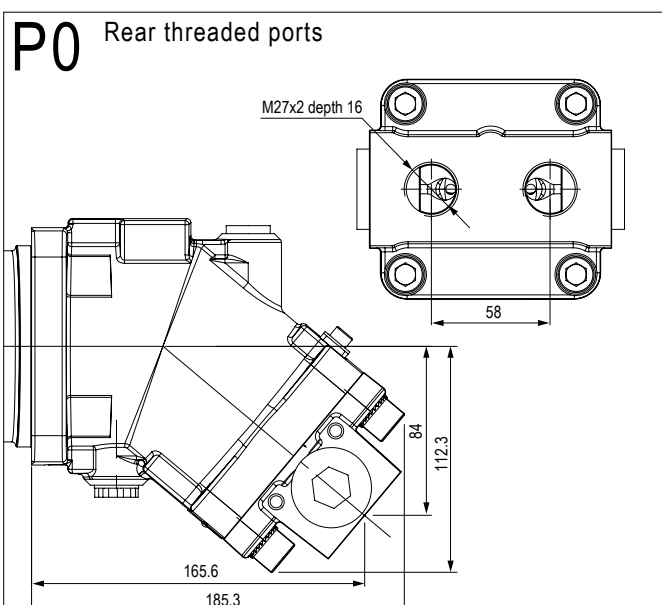
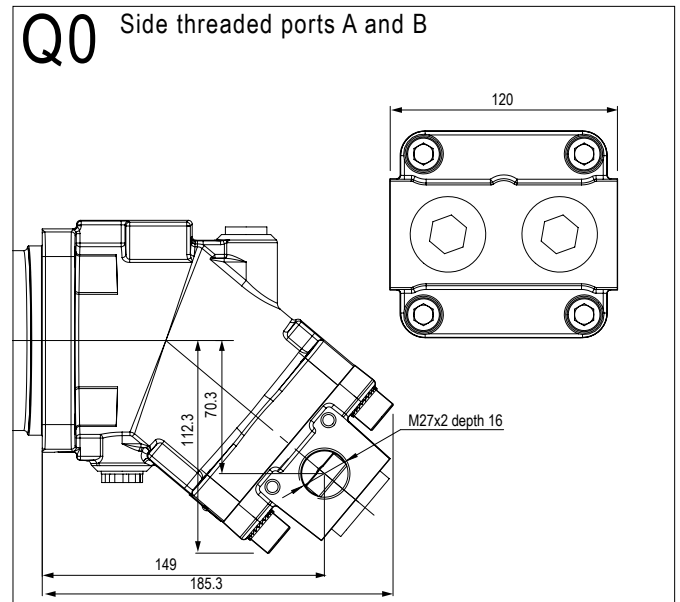
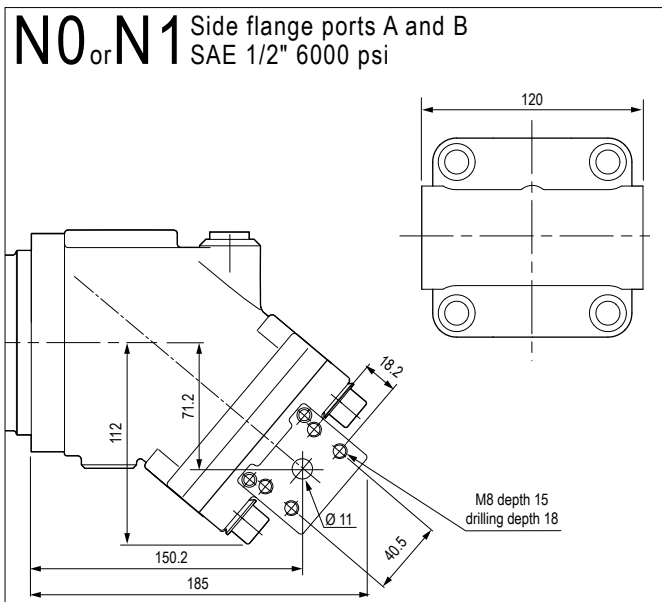
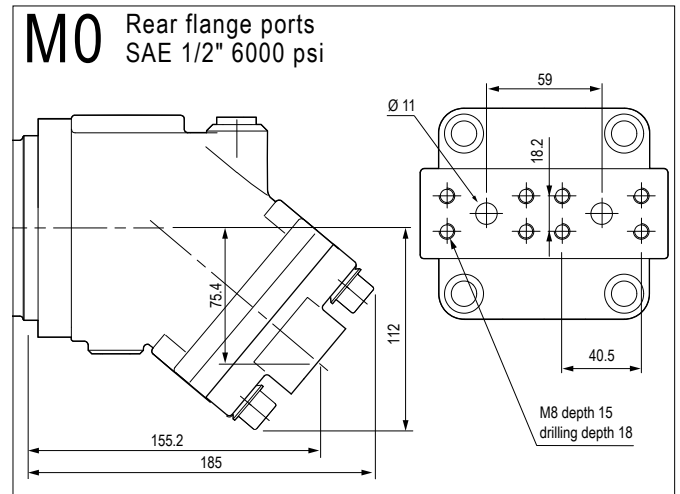
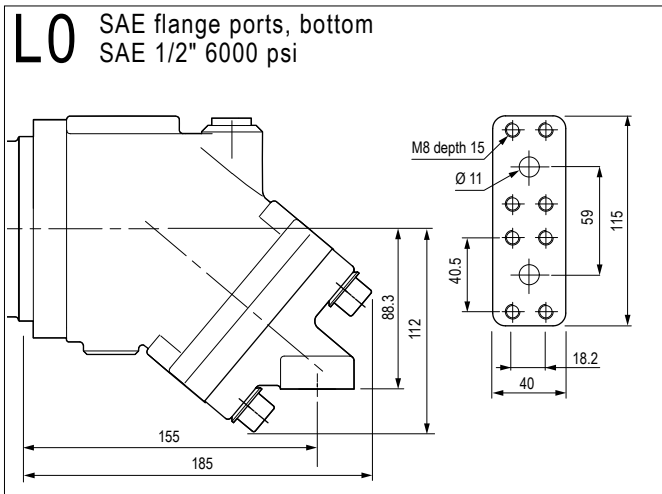

Dimensions in mm are given only as an indication.

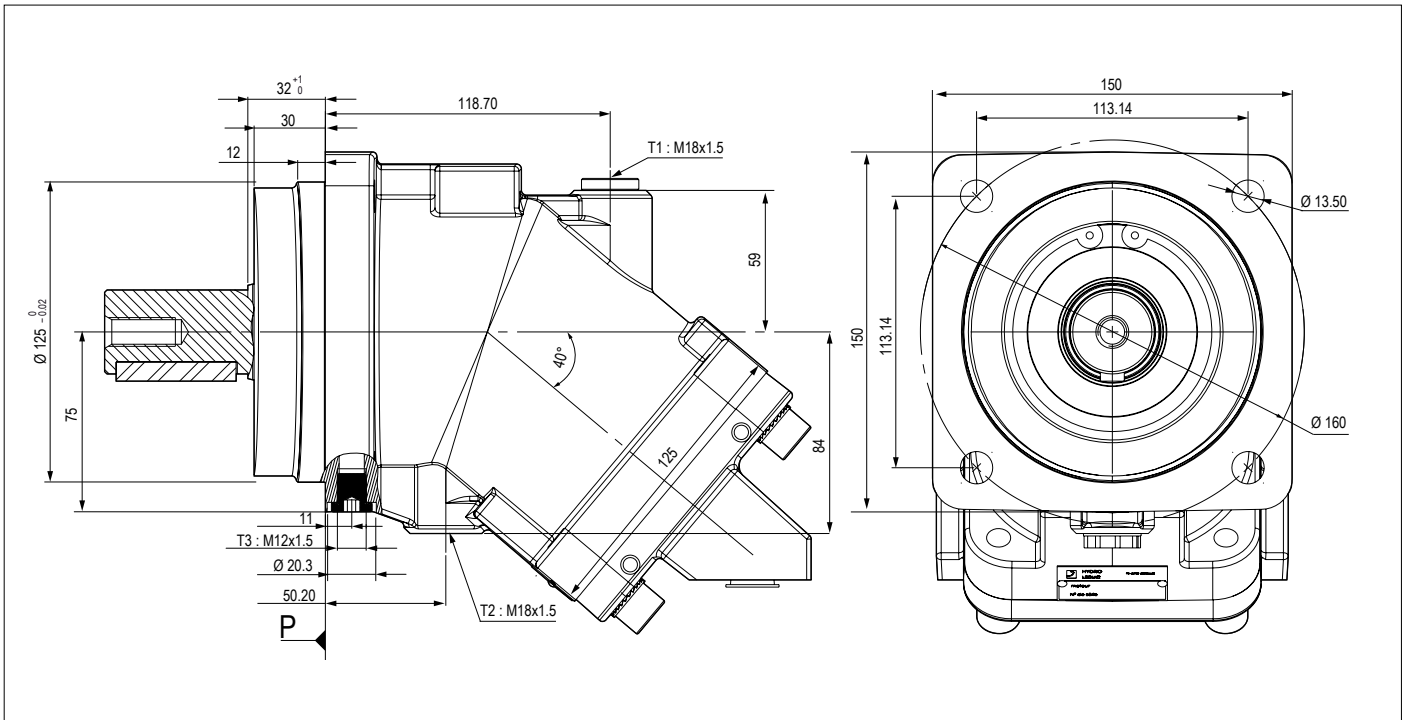

► Shaft end

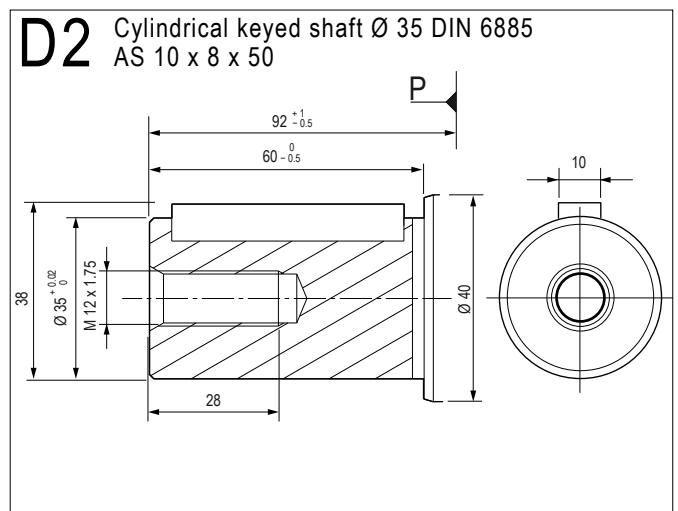
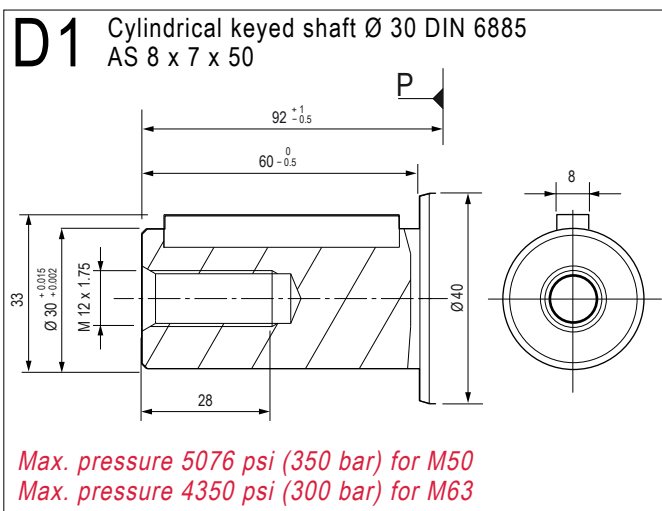
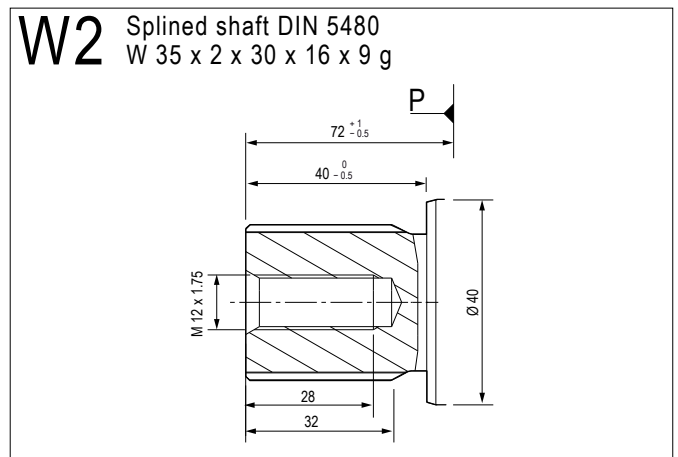
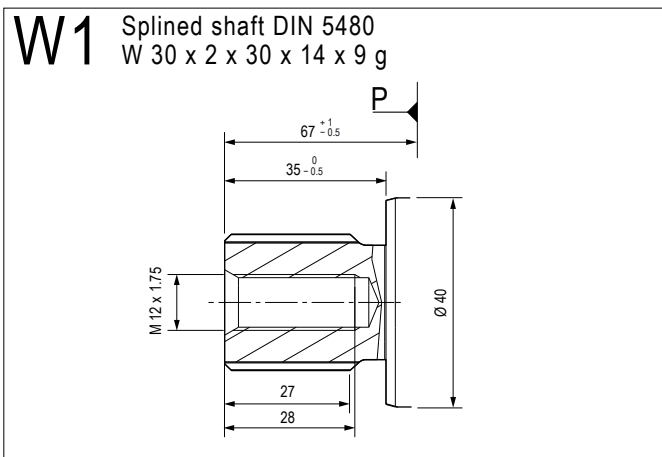

Dimensions in mm are given only as an indication.

► Inlet ports

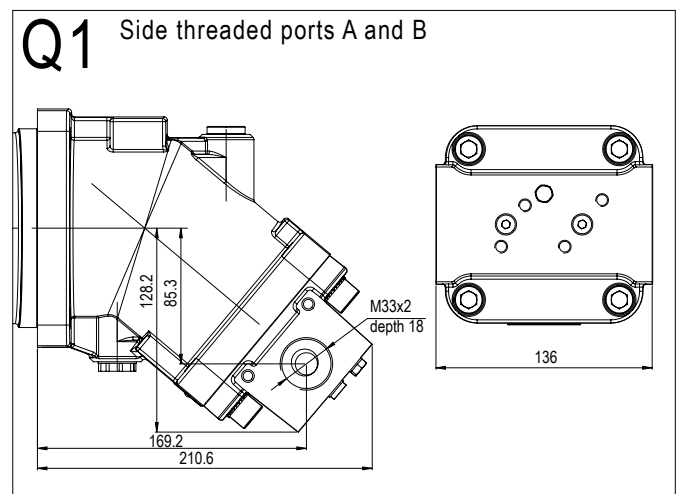
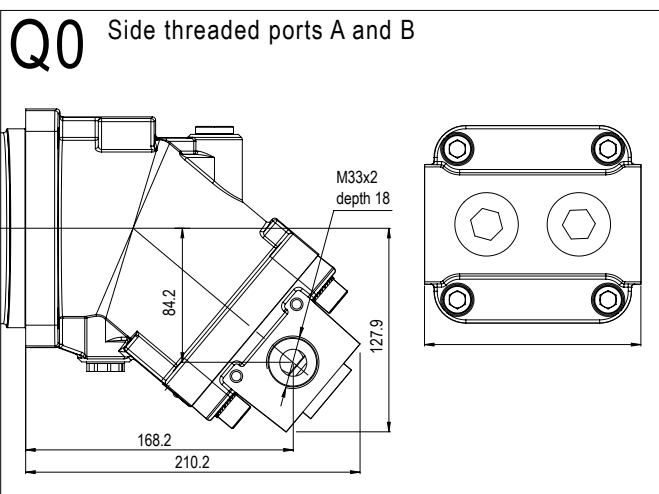
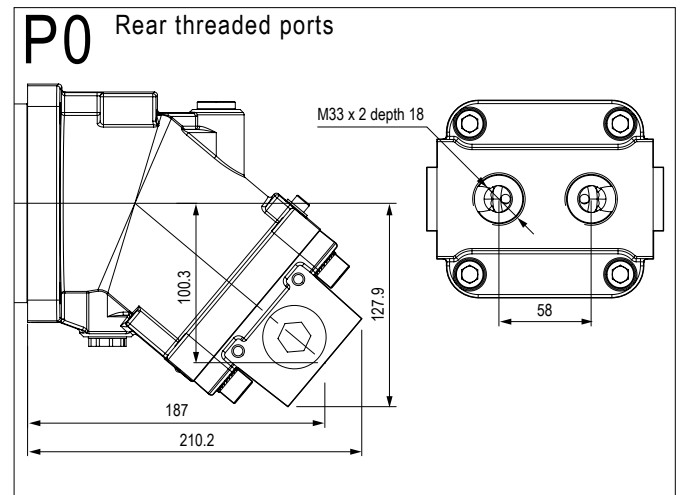
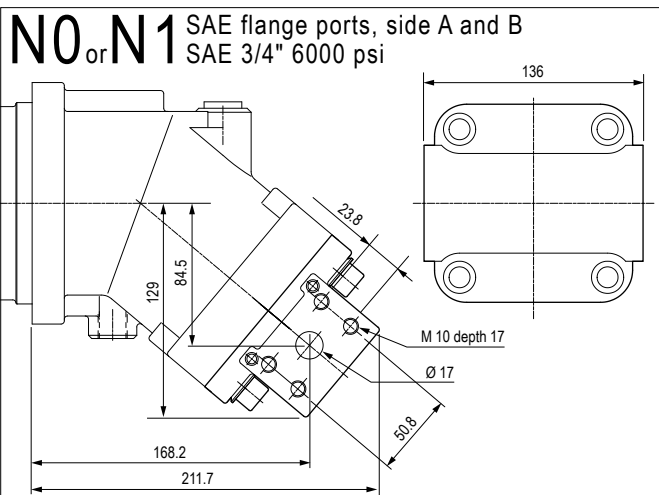
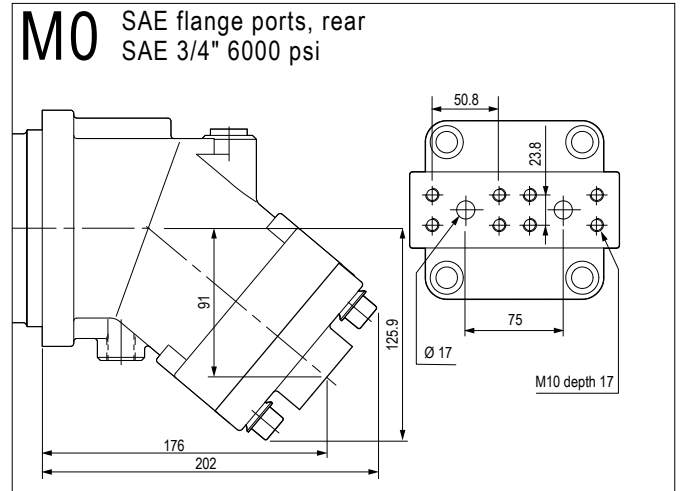
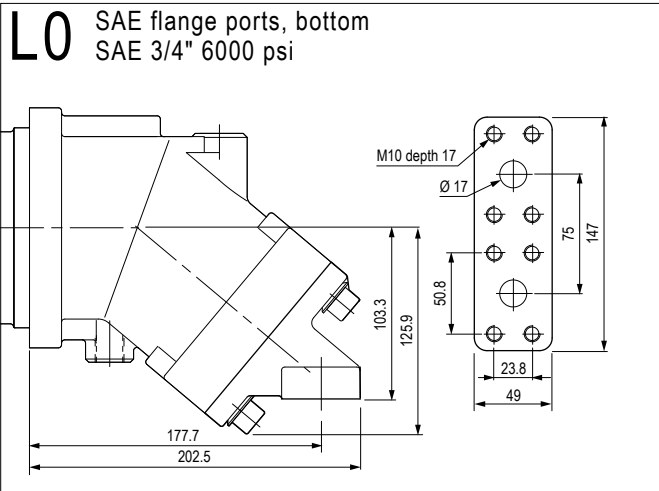

M series

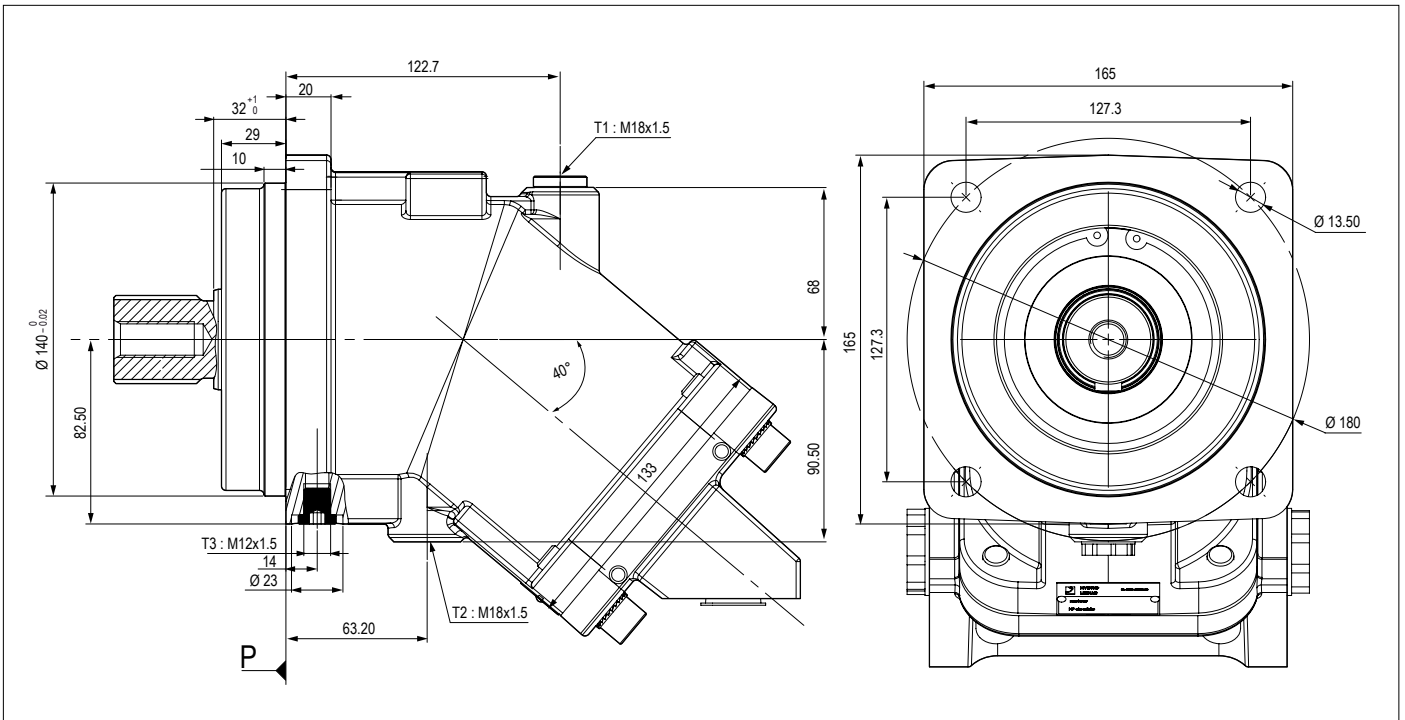

► Shaft end

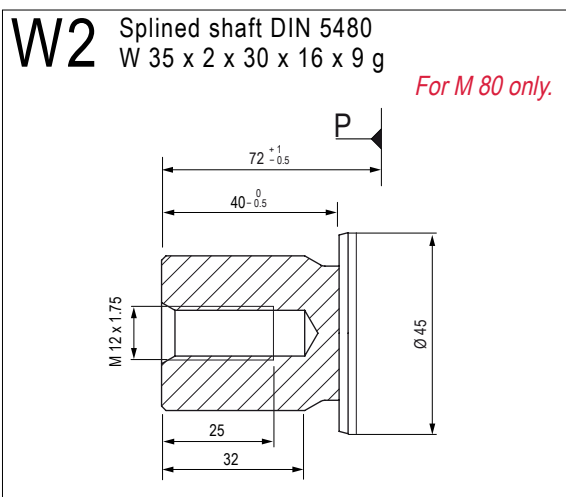
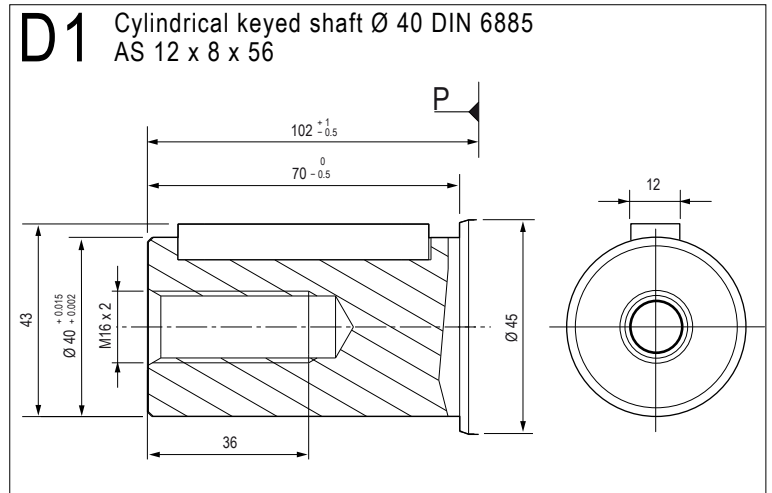
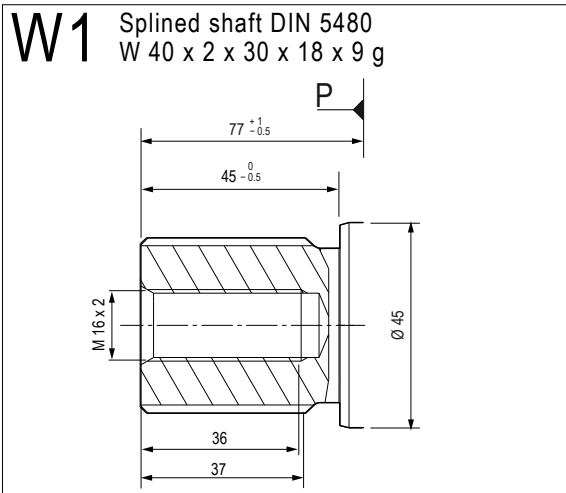

► Inlet ports

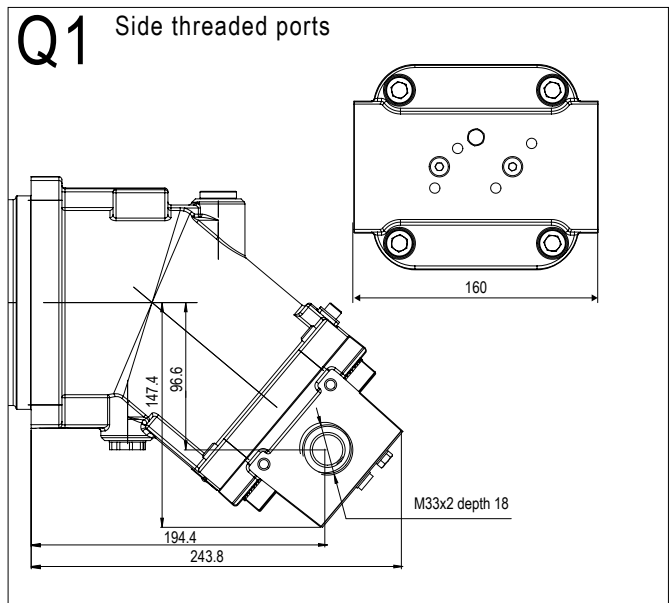
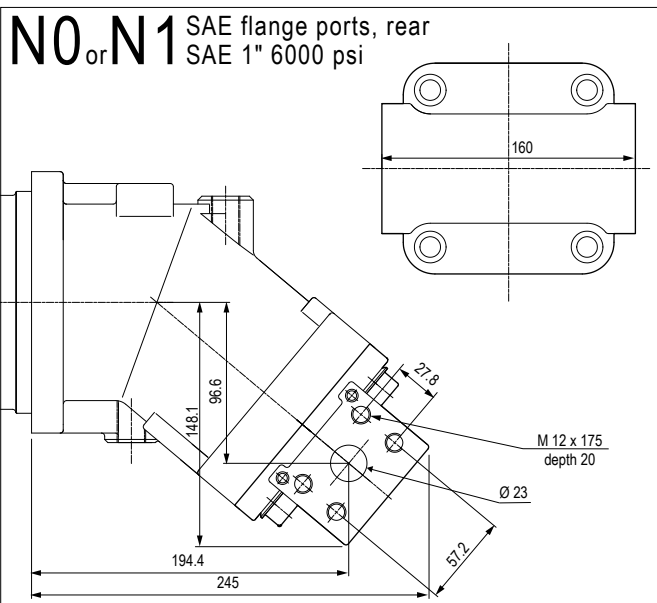
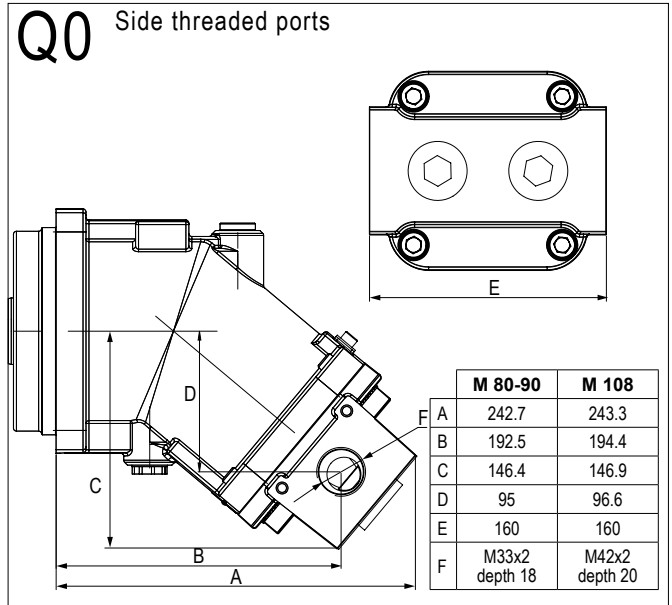
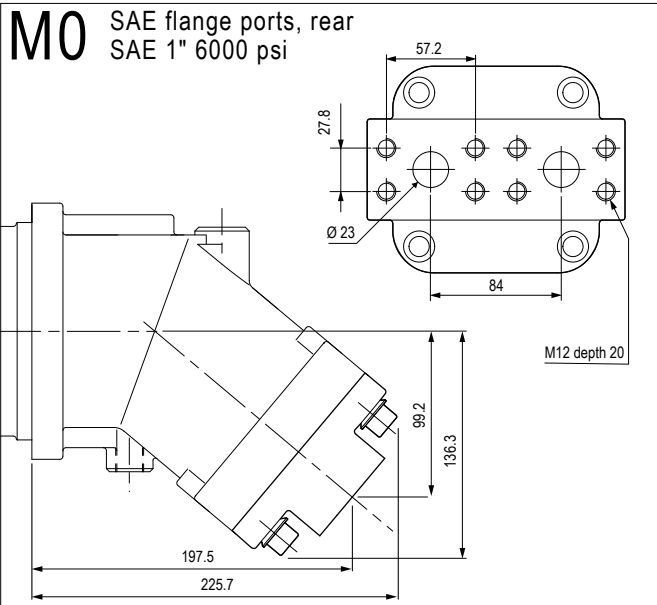
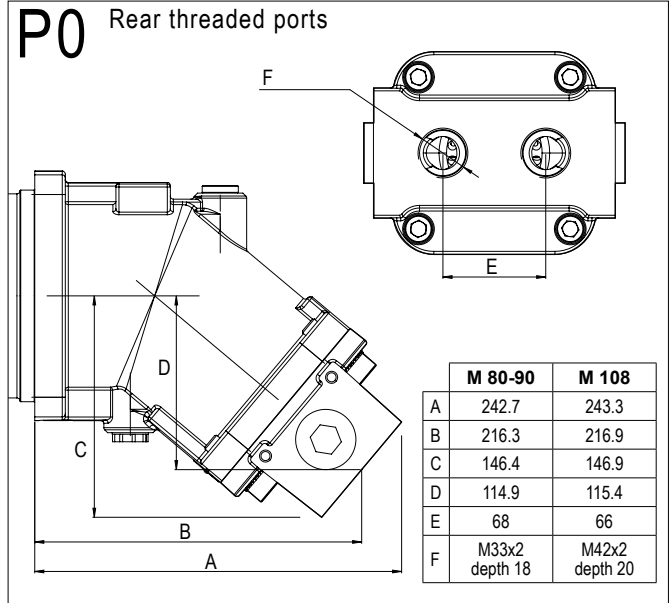
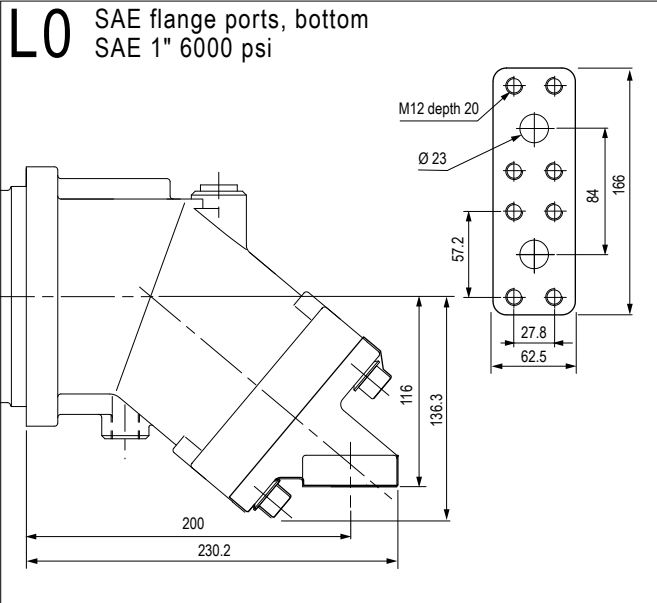

Dimensions in mm are given only as an indication.

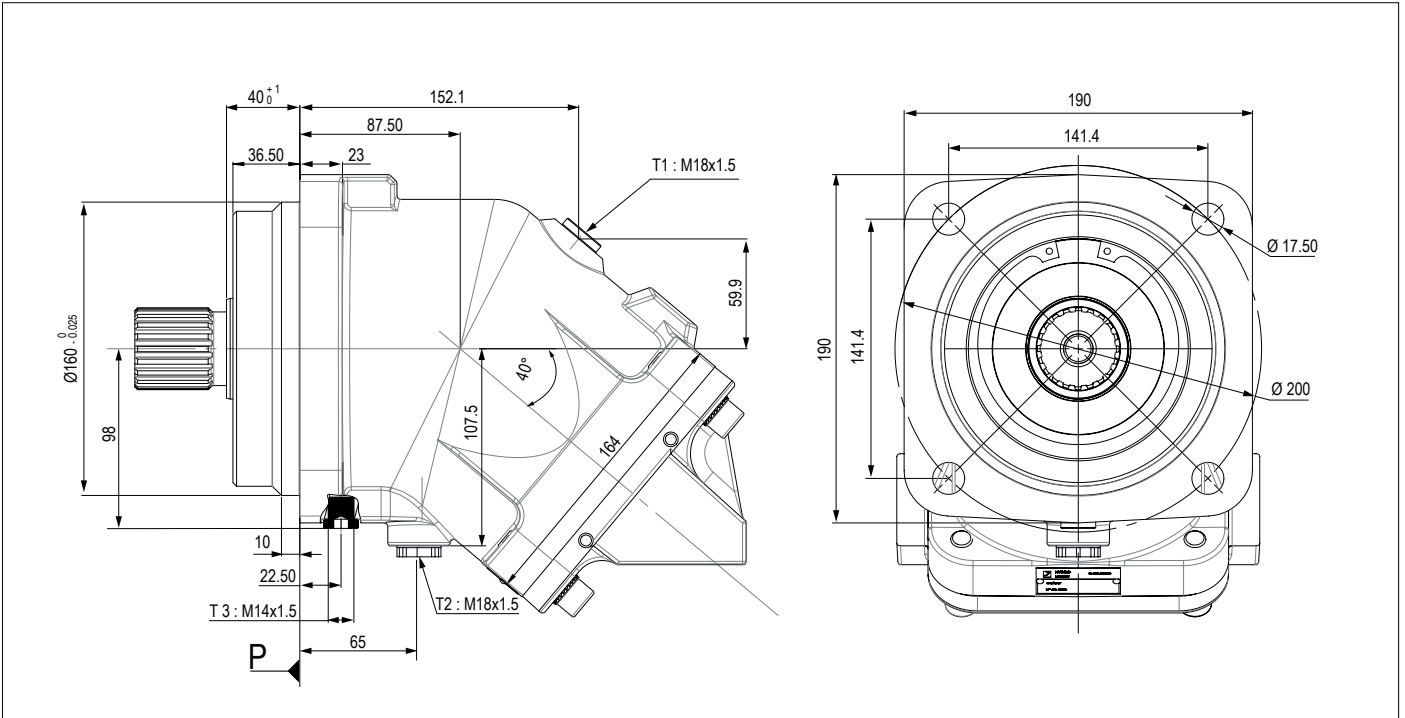

► Shaft end

W1 Splined shaft DIN 5480
W 45 x 2 x 30 x 21 x 9 g

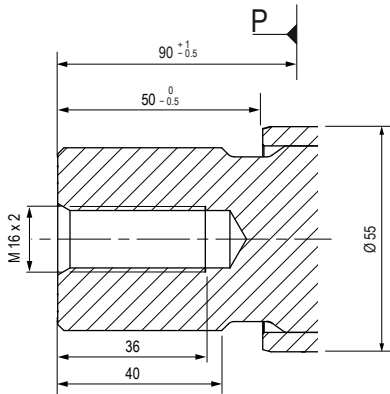

D1 Cylindrical keyed shaft $\varnothing 45$ DIN 6885
AS 14 x 9 x 63

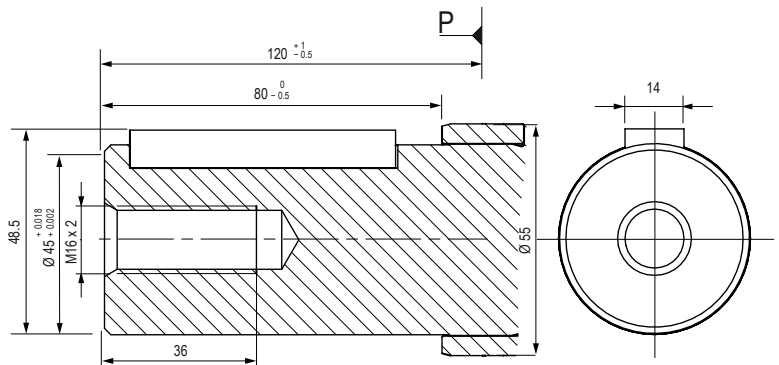

W2 Splined shaft DIN 5480
W 40 x 2 x 30 x 18 x 9 g

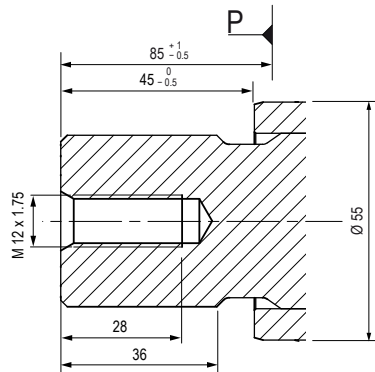

D2 Cylindrical keyed shaft $\varnothing 40$ DIN 6885
AS 12 x 8 x 56

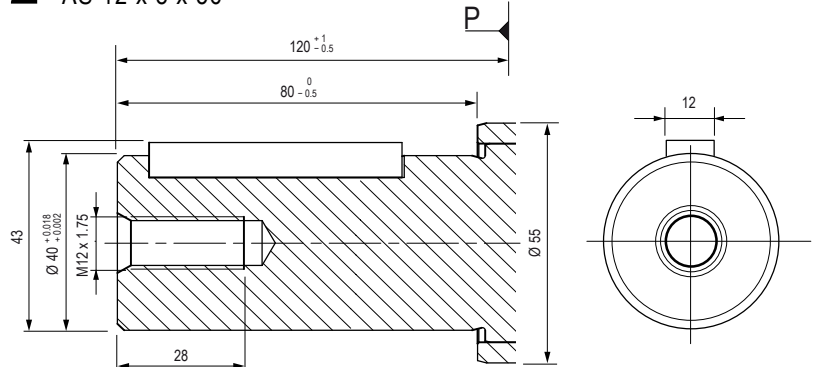

Max. pressure 5076 (350 bar) for M 125.

For M 108 R only.

M 108 R - 125

► Inlet ports

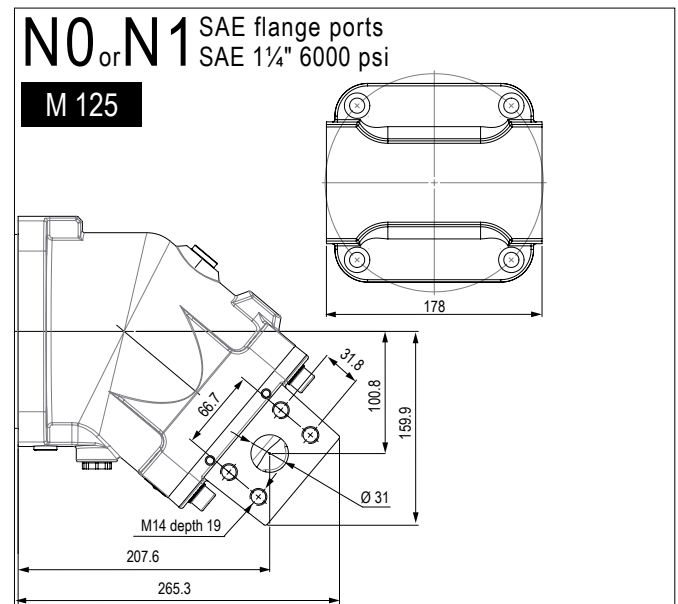
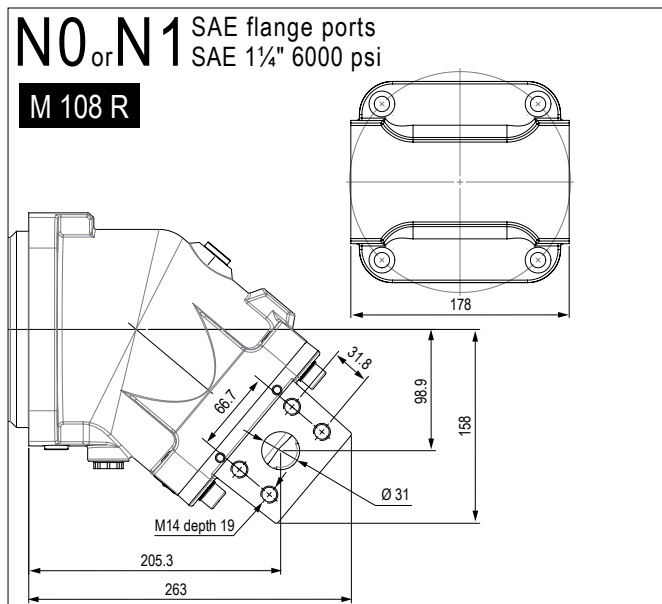
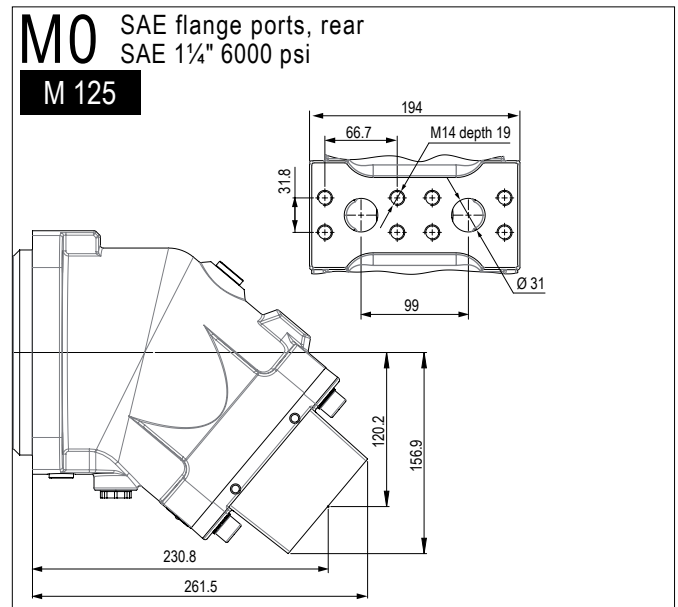
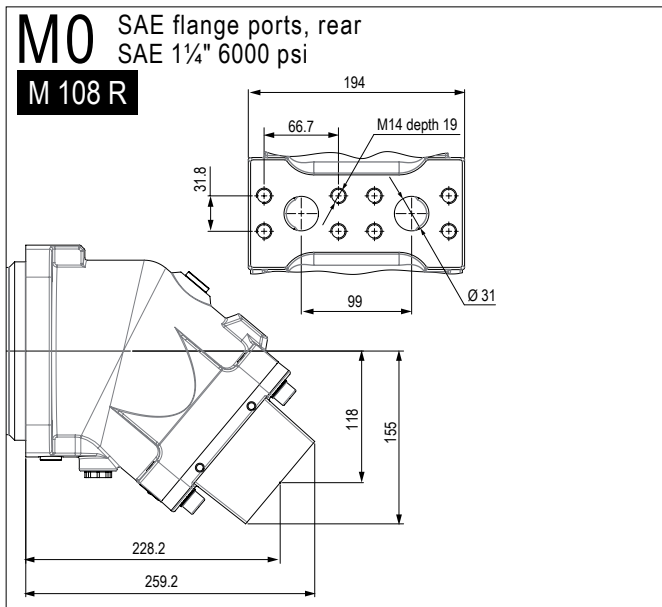
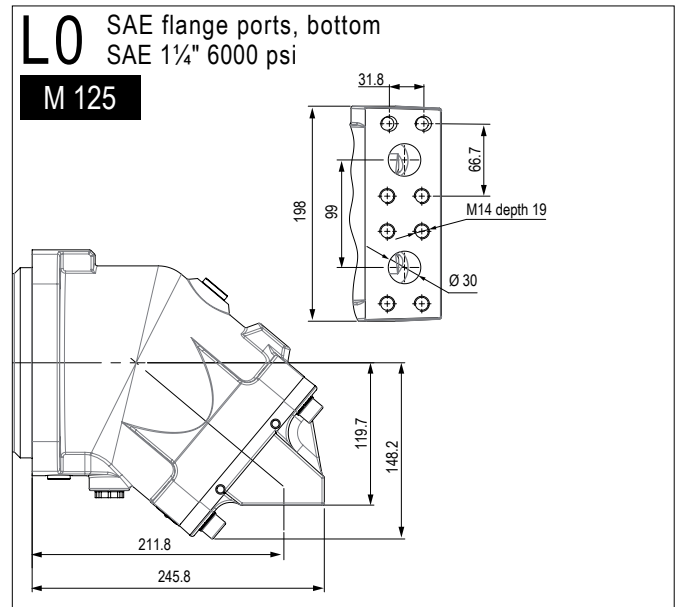
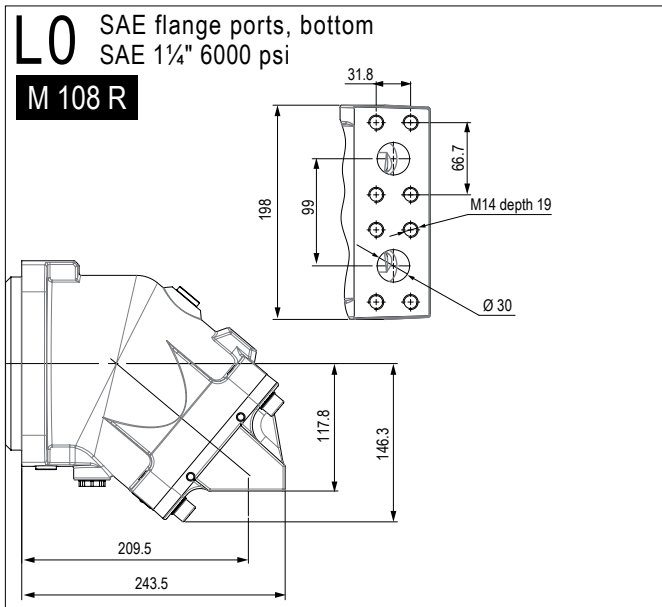

Dimensions in mm are given only as an indication.

► Inlet ports

