

Gear pumps

Gear pumps Group I Right

## Gr.I Gear pump/ Eur.flange/tapered shaft 1:8 /threaded side ports type

Page: 1/2

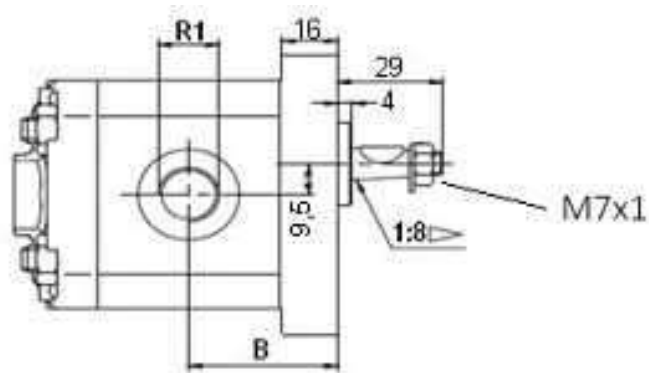
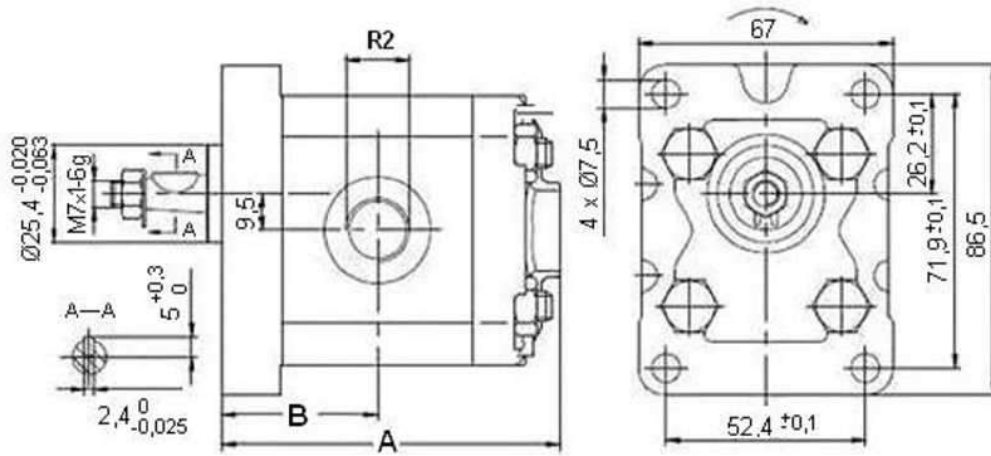

**Rotation reference:** BTD...I=Rotation left  
BTD...D=Rotation right

Min 600 rpm

**Flange and cover:** Alluminum

Gear pumps

Gear pumps Group I Right

## Gr.I Gear pump/ Eur.flange/tapered shaft 1:8 /threaded side ports type

Page: 2/2

Part nº	R1	R2	Max. Press. (bar)	Max. Peak press.	R.P.M.	cm <sup>3</sup> / rev	A	B
<b>BTD111D01</b>	3/8" BSP	3/8" BSP	250	300	6000	1,1	75	33
<b>BTD116D01</b>	3/8" BSP	3/8" BSP	250	300	6000	1,6	78	35
<b>BTD118D01</b>	3/8" BSP	3/8" BSP	250	300	6000	1,8	78,5	35,5
<b>BTD127D01</b>	3/8" BSP	3/8" BSP	250	300	6000	2,7	81	37
<b>BTD132D01</b>	3/8" BSP	3/8" BSP	250	300	5000	3,2	83	38
<b>BTD137D01</b>	3/8" BSP	3/8" BSP	250	300	4500	3,7	85	39
<b>BTD148D01</b>	3/8" BSP	3/8" BSP	200	250	4000	4,8	89	41
<b>BTD158D01</b>	1/2" BSP	3/8" BSP	200	250	3500	5,8	93	43
<b>BTD163D01</b>	1/2" BSP	3/8" BSP	200	250	2900	6,3	97	45
<b>BTD180D01</b>	1/2" BSP	3/8" BSP	200	250	2100	8	101	47

\*R.P.M.=Máx. speed  
R1 = inlet, R2 = outlet  
Tightening torque 25-30 Nm