

Gear pumps

Gear pumps Group II Right

Gr.II Gear pump/Eur.flange/Tapered shaft 1:8 /Threaded Side ports type

Page: 1/1

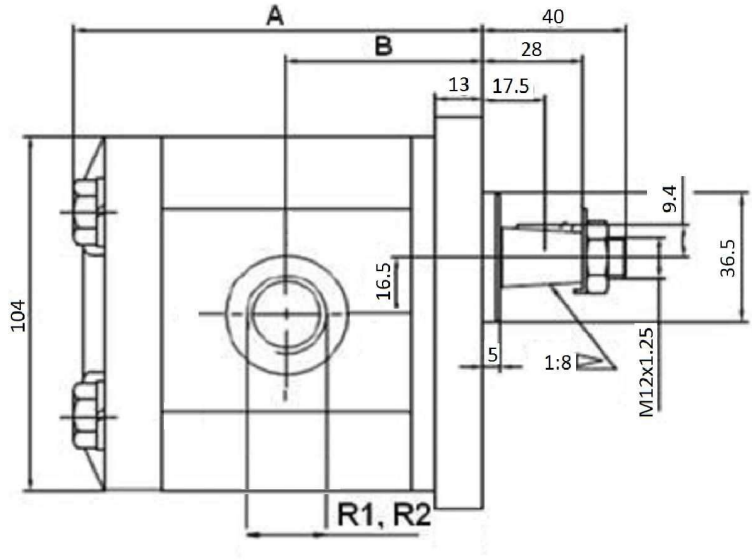
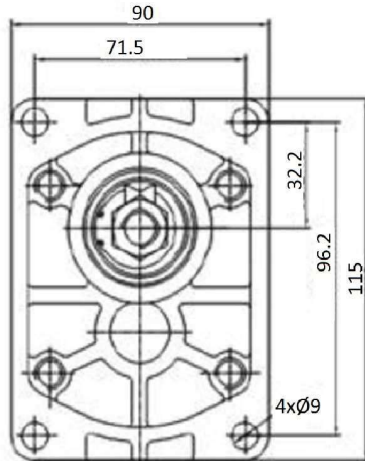

Rotation reference: BTD...I=Rotation left
BTD...D=Rotation right

Min 500 rpm

Flange and cover: Alluminum

Part n°	R1	R2	Max. Press. (bar)	Max. Peak press.	R.P.M Max	cm ³ / rev	A	B
BTD240D01	1/2" BSP	1/2" BSP	250	300	3500	4	95,5	43,3
BTD260D01	1/2" BSP	1/2" BSP	250	300	3500	6	99	45
BTD280D01	1/2" BSP	1/2" BSP	250	300	3500	8	102	46,5
BTD2100D01	1/2" BSP	1/2" BSP	250	300	3500	10	105	48
BTD2120D01	1/2" BSP	1/2" BSP	250	300	3500	12	108	49,5
BTD2140D01	3/4" BSP	1/2" BSP	250	300	3500	14	111	51
BTD2160D01	3/4" BSP	1/2" BSP	250	300	3500	16	114	52,5
BTD2200D01	3/4" BSP	1/2" BSP	250	300	3500	20	121	56
BTD2230D01	3/4" BSP	1/2" BSP	200	250	3000	23	125,5	58,3
BTD2250D01	3/4" BSP	1/2" BSP	200	250	3000	25	128	59,5
BTD2280D01	3/4" BSP	1/2" BSP	160	200	3000	28	133	62
BTD2300D01	3/4" BSP	1/2" BSP	160	200	3000	30	136	63,5

(*) R1 = inlet; R2 = outlet
DECIBELS: 70 dB
Tightening torque 45-50 Nm